

G26 AMBIENT OIL MIST DETECTOR

LINE-OF-SIGHT OPACITY METER FOR
MONITORING OF OIL MIST IN OPEN SPACES

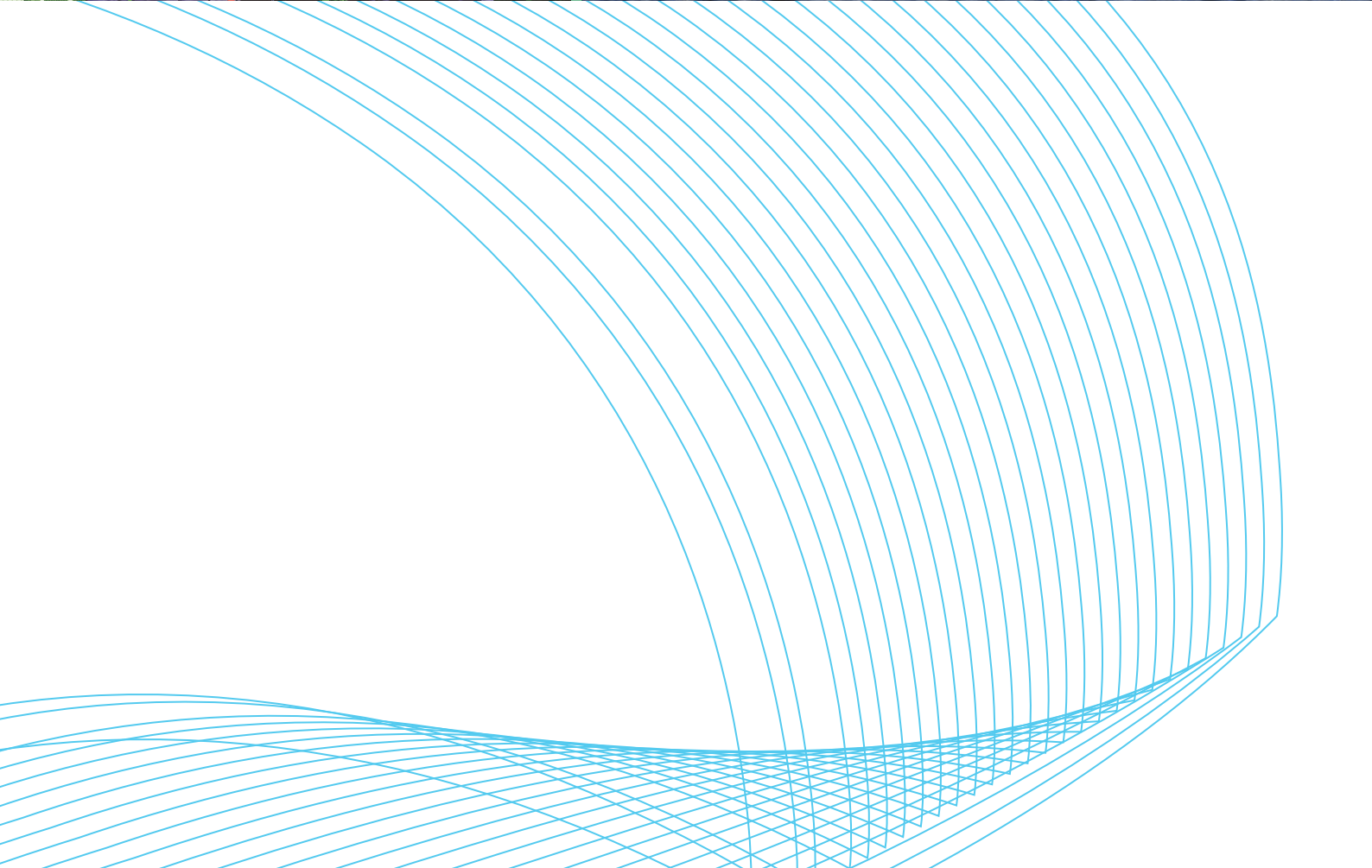

COST-EFFECTIVE PROTECTION



KEY FEATURES

- **Graphic visualization for atmospheric oil mist conditions**
- **Compliant with inspection programs such as SIRE**
- **Large area coverage per detector**
- **Number of detectors per monitor configurable**
- **Lens cleaning alarm and oil mist alarm**
- **BUS communication**
- **Easy to install - optional installation kit**
- **User-friendly interface with touch screen**
- **Easy cleaning of open lenses**
- **Robust design with low maintenance cost**

APPROVALS AND CERTIFICATES

- **Type Approval for Marine, Offshore and Industrial Applications in progress**

DETECT OIL MIST IN OPEN SPACES

The G26 Ambient Oil Mist Detector is an opacity meter which is designed to monitor oil mist in open spaces. The system uses the latest green and solid laser technology with the double pass measurement method. The system provides the measurement in units of opacity (0-100%) and oil mist content in mg/l based on specific oil types according to ISO16437:2012.

COVER LARGE AREA - RELIABLE OPERATION

The G26 has the several decisive advantages compared to the single point extractive sampling system. Each detector can cover a much larger area. The scanning distance of a detector is from 1 to 15 meters. The G26 can be configured with a number of detectors, allowing the system to monitor the oil mist in several different locations at the same time.

Besides, the line of sight measurement does not require any sampling devices. This feature minimizes the system operating faults causing by any parts of the sampling devices including the mechanical or contamination problems over time. The double pass opacity meter is known with its reliability, high accuracy and precision since it detects the real undiluted oil mist clouds in the atmosphere.

FOR HYDRAULIC INSTALLATIONS AND FUEL LINES



SIMPLE INSTALLATION - LOW MAINTENANCE

The installation of the G26 Ambient Oil Mist Detector is very simple. The system has an optional installation kit. The kit includes a power bank to enable the transceiver to send a continuous visual green light beam during installation for easy alignment.

With no moving parts, the system does not require much maintenance except occasional cleaning of the lenses and calibration. The G26 Ambient Oil Mist Detector is designed purposely to marine application thus the system is robust while operating in the extreme working environment at sea.

PREVENT FIRE HAZARD

Early alarms on the formation of oil mist at the atmosphere are important to identify the risk of fire hazard, especially at the locations with high potential generation of oil mist such as engine rooms, oil purifying rooms, and hydraulic pump rooms on board ships, as well as fixed and floating offshore platforms.

The monitor of the G26 has an HMI module for visualization and operation. The graphic visualization on the home screen shows an immediate overview of the atmospheric oil mist conditions in different locations under detection. The feature provides possibility for quick handling of any minor oil leakage much earlier before any alarms come.

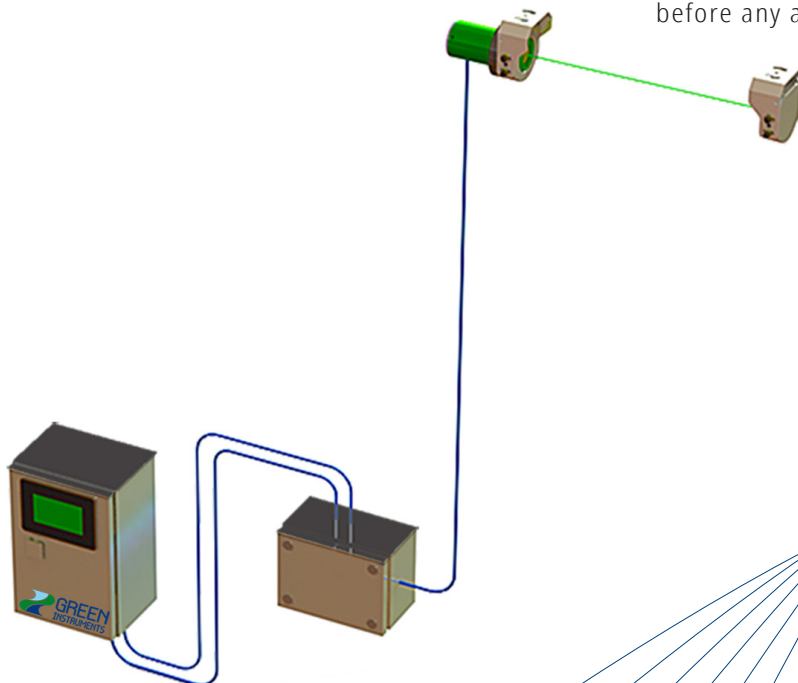

SPECIFICATIONS - G26

MONITORING AND CONTROL UNIT

Power supply	Standard 20 - 30 VDC - 50/60 Hz - 1.4 A - optional 100 - 240 VAC
Ambient temperature	0 - 55 °C
Communication	MODBUS TCP/IP
Analog output (active & linearized)	2 x 4 - 20 mA (4 mA \approx 100 % – 20 mA \approx 0 % Opacity) max. 500 Ω Optional: 0 - 10 VDC (0 V \approx 100 % – 10 V \approx 0 % Opacity)
Relay output	4 relays, NC/NO, max. load: 10 A - 250 VAC
Default alarm level	at 5 % and 10 % opacity
Alarm delay	Default 5 s /programmable (0 - 99 s)
Digital input	6 x Sink/Source inputs
Display	Opacity: 0 - 100 %, Extinction, and Density: mg/l
Accuracy	Better than 2 % of full scale
Enclosure	IP 65 steel box
Dimensions	H×W×D: 300x200x150 mm/5.0 kg

TRANSCIEVER

Measuring range	0 - 100 % Opacity
Measuring principle	Transmission
Ambient temperature	0 - 55 °C
Protection	IP 66
Dimensions/weight	OD 600 mm, length 125mm/Kg
Scanning distance	1.0 to 15.0 m

ASSESSORIES AND OPTIONAL

Assessories	Reflector module Aligment & supporting brackets
Optional	Audit module; Remote digital display; Audio alarm buzzer Visualization, recorder and data logging

Specifications subject to changes without notice

EUROPE

Green Instruments A/S
sales@greeninstruments.com
Erhvervsparken 29
9700 Brønderslev, Denmark
Tel: +45 96 45 45 00

AMERICA

Green Instruments USA, Inc
usa@greeninstruments.com
3640 NE 4th Avenue
Fort Lauderdale, FL-33334, USA
Tel: +1 954 613 0400