

# SPECIFICATIONS - G4130

## ANALYZER

---

<b>Measurement range</b>	NOX: 0...1500 ppm (F.S.) - O <sub>2</sub> : 0.0...21.0 % (F.S.)
<b>Power supply</b>	100...230 VAC - 50...60 Hz or 24 VDC. Consumption max. 40 VA per analyzer
<b>Output signal</b>	2×4...20 mA-range selectable - Default: O <sub>2</sub> : 0.0...25.0 % - NOX: 0.0...2000 ppm
<b>Max. load signal</b>	600 Ω / 24 VDC
<b>Alarm relays</b>	Volt free, 24 VAC/DC, 5 A
<b>Display</b>	Touch screen 71×39 mm with trend graph display
<b>Ambient temperature</b>	-0...55 °C
<b>Dimensions</b>	H×W×D: 170×200×90 mm. Cable glands at bottom
<b>Enclosure</b>	Aluminum casing IP67

## ANALYZING BOARD

---

<b>Dimensions/weight</b>	H×W×D: 600×500×140 mm/approx. 10.0 kg without packaging
<b>Span NOX gas connection</b>	6/4 mm tubing - max. 1 bar
<b>Air supply filter regulator</b>	1/8" BSP connection - max. 1 bar
<b>Air supply quality</b>	Instrument air quality according to ISO 8573-1

## DIFFUSION PROBE

---

<b>Sensor technology</b>	Heated zirconia type sensor
<b>Sample temperature</b>	0...500 °C
<b>Probe insert length</b>	Approx. 208...338 mm - for duct diameters 235...2800 mm
<b>Mounting type</b>	Welding socket size OD: 70.0 mm L: 190 mm or thread size: 1½" BSP
<b>Air supply connection for back-flushing &amp; calibration</b>	6/4 mm tubing
<b>Calibration gas flow</b>	Approx. 0.5...1.0 l/min
<b>Dimensions short/long</b>	Short: 285×180×475 mm (H×W×D) Long: 285×180×600 mm
<b>Weight</b>	Approx. 6.0 kg without packaging

## UMBILICAL CORD

---

<b>Length</b>	3.0 m
<b>Tubing</b>	28 mm nylon conduit

Specifications subject to changes without notice



WWW.GREENINSTRUMENTS.COM - SALES@GREENINSTRUMENTS.COM  
ERHVERVSPARKEN 29 DK-9700 BRØNDERSLEV  
TEL: +45 96 45 45 00 FAX: +45 96454501



# G4130 NOX/O2 ANALYZING SYSTEM

COST-EFFECTIVE EMISSION CONTROL  
FOR GREEN IMAGE & FUEL EFFICIENCY

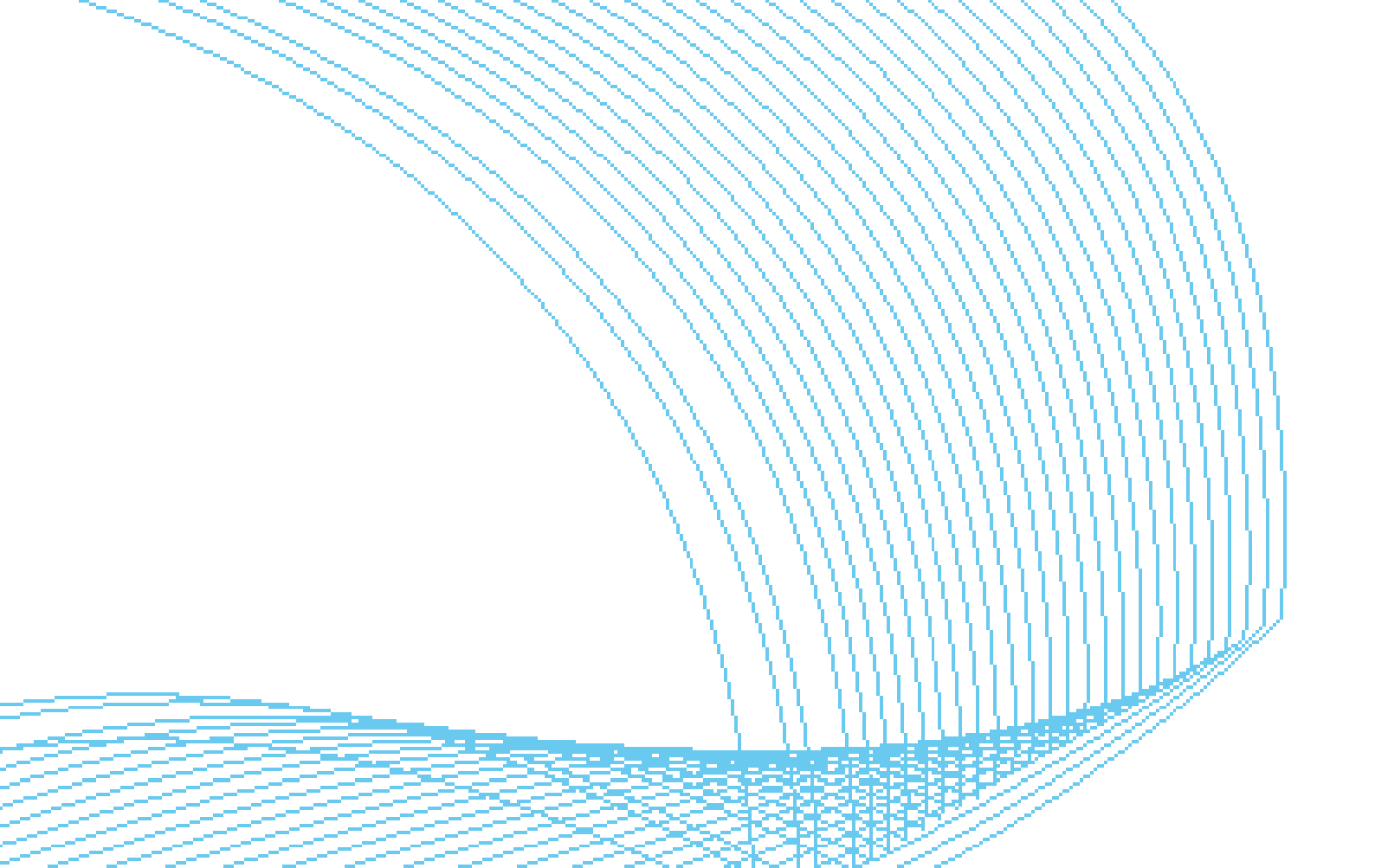

# ROBUST TECHNOLOGY & SIMPLE DESIGN



## KEY FEATURES

- In situ and direct monitoring
- Reliable true wet measurements of NOX and O2 in flue gas
- No sample lines, sample systems or converters
- Plug'n'play - easy installation and integration
- Easy operation with LCD touch screen
- Automatic back flushing and purging of the probe
- Analog outputs
- Low cost of ownership
- Provides data for SCR/combustion optimization

## COST-EFFECTIVE GAS ANALYZER

The G4130 NOX/O2 Analyzing System monitors NOX and O2 concentrations in emissions gas.

The NOx analyzer provides a cost-effective solution to help fulfill tightening emission regulations as well as supporting the most effective operation for all types of combustion processes. It is designed to meet the challenging requirements for monitoring the inlet and outlets of selective catalytic reduction systems (SCR) on all types of combustion sources.

## SIMPLE, IN SITU SYSTEM

The system uses a zirconium oxide sensor with multiple diffusion cells. The sensor is small and robust and can be installed directly on the stack without special protection.

The technology allows in situ, real-time measurement of NOX and O2 on wet basis at high temperatures. This avoids sampling lines and multiplexing systems, coolers and converters with all their disadvantages.

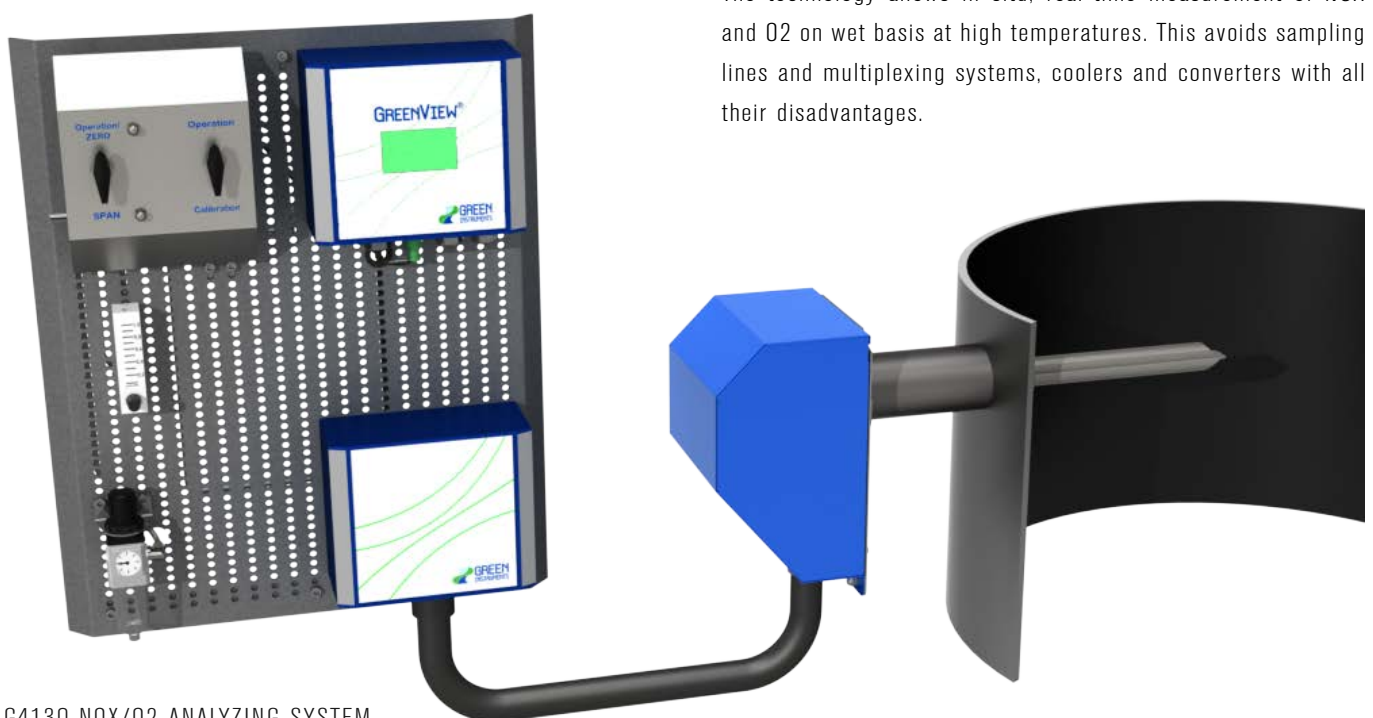

G4130 NOX/O2 ANALYZING SYSTEM

# COMPLY WITH TIGHTENING EMISSIONS REGULATIONS



## COMPLY WITH ENVIRONMENTAL STANDARDS

The G4130 NOX analyzer is designed in compliance with the NOX Technical Code 2008 and the analyzer is type approved by Lloyd's Register and Det Norske Veritas. It provides you with real time data on NOX in ppm and O2 in percent. This data can be integrated in a visualization & analyzing system.

## HOW TO COMPLY WITH MARPOL ANNEX VI

Using the G4130 NOx analyzer in combination with an emissions abatement system like a selective catalytic reduction or exhaust gas re-circulation system will allow constant optimization of the engine and other operating parameters.

Real time emission data from the NOx analyzer provides important input for diagnostics of both the engine and the after-treatment equipment.

## EASY REPORTING WITH THE G49xx

As an optional extension to the G4130, Green Instruments offers the G49xx Visualization & Reporting Family which is a modular system that provides tailor made solutions. The requirements for emissions reporting are different from application to application.

## THE DIFFUSION PROBE

The design of the diffusion probe ensures less and easy maintenance. Depending on the diameter of the exhaust pipe we can offer the G4130 with a long or a short probe.

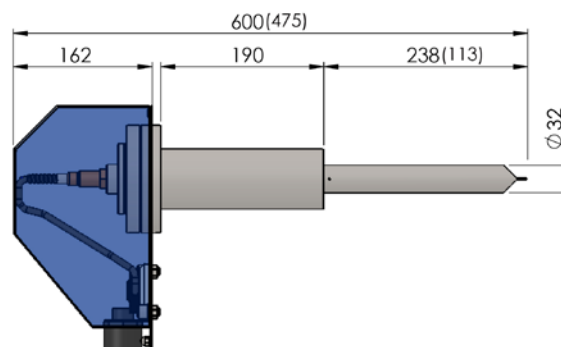

G4130 NOX/O2 - long probe (short probe)

