

HEAT TRANSFER & NO_x REDUCTION SYSTEMS



GESAB produces and delivers complete heating & NO_x reduction systems. The package includes conceptual studies, project plans, specifications, P&ID's class and construction drawings and operating manuals. All necessary valves, fittings, pressure vessels, pumps and auxiliary equipment are included in the delivery package. GESAB uses a proprietary computer program for heating coil calculations to optimize the design and minimize the cost.

BUSINESS CONCEPT AND QUALITY POLICY

GESAB's business concept is to develop, optimize and offer marine and industrial heating & NO_x reduction systems that fulfill the needs of our customers.

GESAB's primacy as a successful supplier is established through a series of activities from marketing, feasibility studies, advanced calculations, system design, construction and timely delivery.

GESAB works to enhance marine consultant's knowledge base, to influence system solutions presented in ship specifications and to market these solutions towards ship owners and shipyards. The ultimate goal is to always be on the Makers List as a preferred supplier.

The name GESAB should also be associated with a service-minded and experienced staff that delivers reliable, well-tested and cost-effective heating & NO_x reduction systems.

The quality of our products should always meet, or exceed, the customer's expectations.

ENVIRONMENT POLICY

Work methods and material will always be selected with the maximum consideration of the environment for the full product life cycle.

Technical solutions, combustion process in heaters and chemical properties of the thermal oil shall always be designed for the maximum protection of personnel during construction and operations.

All work methods and materials shall be selected to minimize risks of accidents while eliminating any long term damages to man and nature.



CATAMISER®

Catamiser® is a combined SCR reactor and Economiser. The unit will meet future NO_x requirements according to IMO Tier III and makes the engine system more efficient.

EXHAUST GAS HEATERS (ECONOMIZER)

The exhaust gas heater transfers energy from the flue gases to the heat carrying thermal fluid.

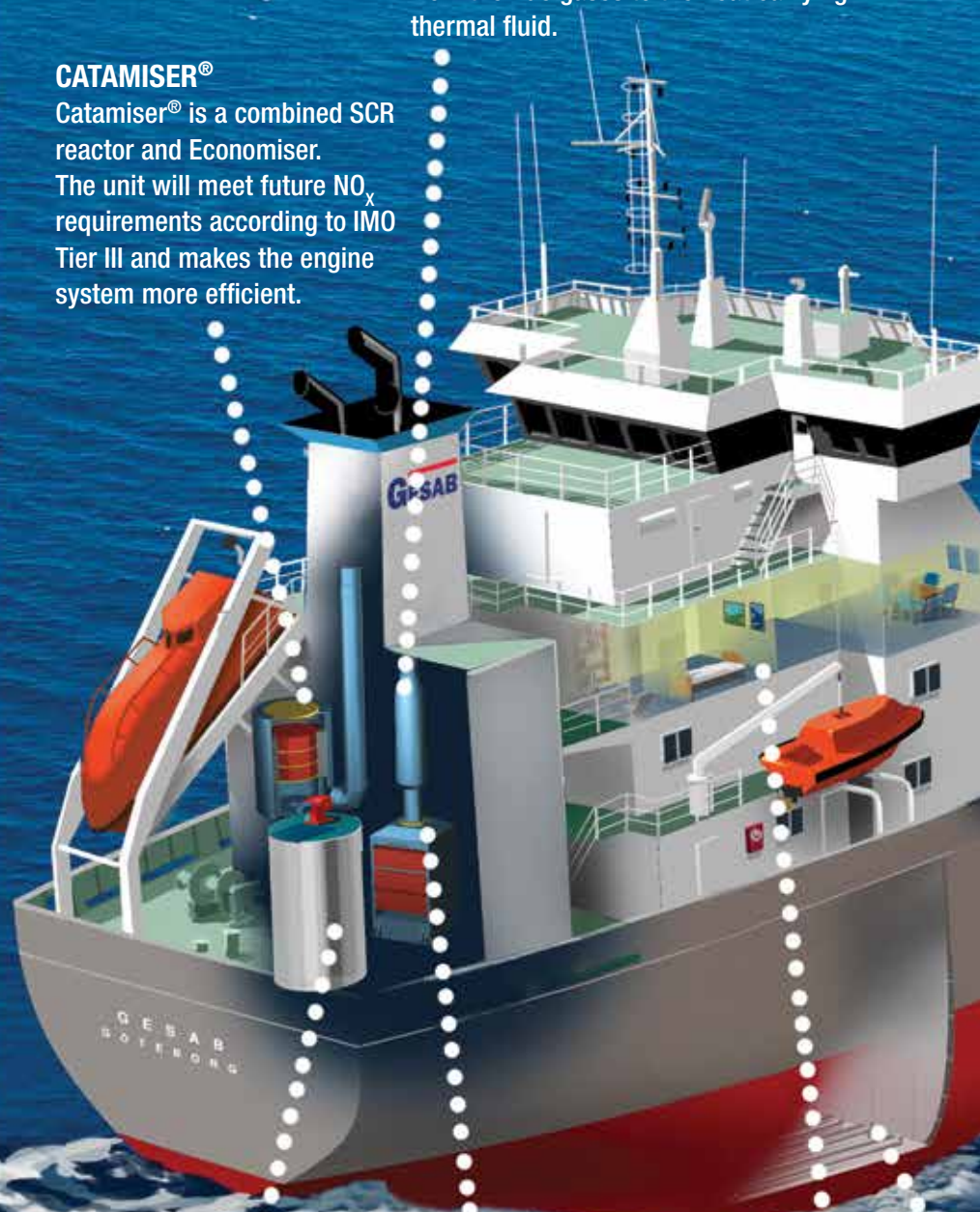

THERMAL FLUID HEATERS

The thermal fluid heaters are built according to the classification society's pressure vessel regulations. The heater is designed as a radiating heater with a succeeding convector heating surface and constructed as a triple-pass flue gas system.

ACCOMMODATION HEATING

Tailor made accommodation heaters provide the optimal indoor climate for personnel and equipment.

SCR (SELECTIVE CATALYTIC REDUCTION)

SCR system reduces NO_x emissions from Diesel engine exhaust gases.

GESAB THERMAL FLUID SYSTEMS ELIMINATE

GESAB THERMAL FLUID HEATING SYSTEM IS PROVEN TO BE ONE OF THE MOST EFFICIENT SYSTEMS FOR MARINE AND INDUSTRIAL USE

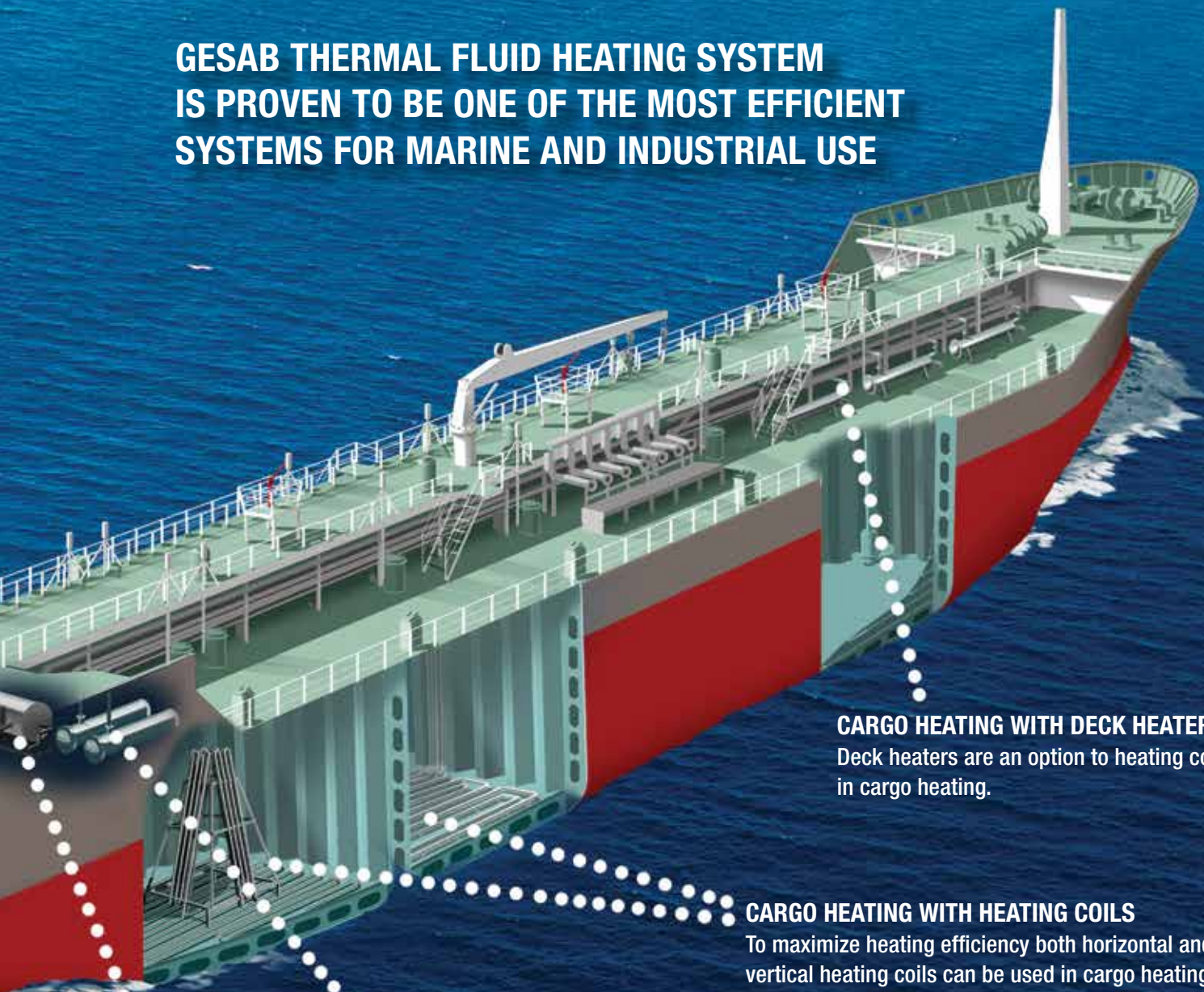

CARGO HEATING WITH DECK HEATERS
Deck heaters are an option to heating coils in cargo heating.

CARGO HEATING WITH HEATING COILS
To maximize heating efficiency both horizontal and vertical heating coils can be used in cargo heating. The pipe materials are stainless steel or carbon steel.

HEATING OF TANK WASHING SYSTEM
The Butterworth heaters feed fixed and mobile washing machines for cargo tank cleaning. The operation is usually designed based on maximum utilization of the heating system.

STEAM GENERATORS
Steam generator for cargo tank cleaning.

BUNKERS HEATING
Heating coils of smooth or fin tube types provide well heated fuel for reliable and economic operations in all waters and climate.

- EASY TO OPERATE AND CONTROL
- CONSIDERABLY REDUCED MAINTENANCE
- EXTENDED LIFE SPAN
- ENVIRONMENTALLY SAFE
- REDUCED HEATING COSTS
- NO CORROSION DAMAGES
- HIGH HEATING TEMPERATURE WITHOUT EXCESS PRESSURE

ALL LIMITATIONS ASSOCIATED WITH TRADITIONAL STEAM SYSTEMS

THERMAL FLUID HEATER

GENERAL

GESAB – HTI Thermal Fluid Heaters are built according to DIN 4754 and the Classification Societies' rules for pressure vessels. The forced circulation heaters of vertical or horizontal design are available for outputs of 100 – 20 000 kW. Thermal Fluid Heaters, with at heating capacity of 800 kW and upward, can use heavy fuel oil burners (viscosity to 700 cSt at 50 C).

On request, we can supply burners with a rotating cups and heaters designed for combustion of waste oil and sludge. Generated heat, by oil or gas flame will be transferred to the thermal fluid system through winded pipes forming cylinders inside the heater.

Within the inner cylinder – the combustion chamber – the heat is transferred by radiation and in the outer cylinder by convection.

DESIGN AND CONSTRUCTION

The radiating heater design employs two helically wound heating coils, fitted into each other and enclosed by a gas tight casing. The outside of the heater consists of a cladding of mineral wool insulated galvanized steel plate. The flue gases are triple-passed over the heating surface and transfer the heat through the tube wall to the heating medium, ensuring high thermal efficiency.



ADVANTAGES

The generously dimensioned combustion chamber guarantees a long heater life due to no flame contact with the heating surface and that no temperature overloading occurs.

An innovative design of the tubes suspension ensures a safe and stress free thermal expansion.

All these design features make the GESAB – HTI Thermal Fluid Heaters an economical and efficient choice.

Heat losses and external surface temperatures of the heater are kept low by the efficient use of insulation mineral wool and sheet metal cladding.

The safety feature eliminates the need for continuous attendance by the operating crew.

STANDARD PROGRAM

Range of output 100 – 20 000 kW

We may also design custom made heaters with higher output capacities.

DESIGN

Vertical or horizontal type depending on physical installation limitations.

VERTICAL FLUID HEATERS

Vertical fluid heaters are used in capacity range of 100 – 10.000 kW. This design is especially suitable to use on small to mid size heaters which are positioned within engine room spaces of ships and drilling rigs where height is not an issue.



Vertical fluid heater is top fired, where the burner is mounted in vertically position from top down.

DIMENSION SKETCH THERMAL FLUID HEATER

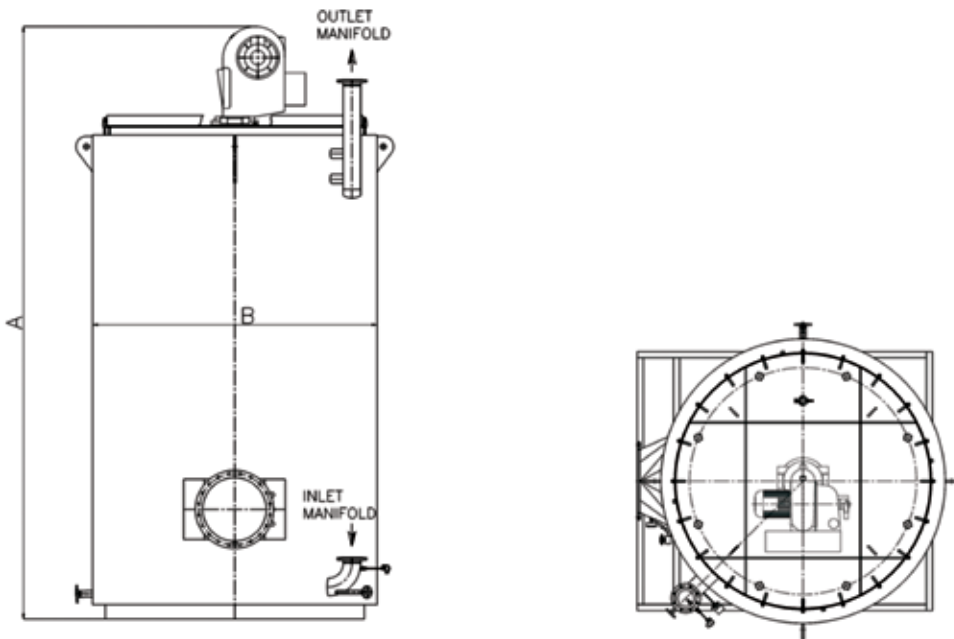

TABLE OF DIMENSIONS THERMAL FLUID HEATER

TYPE	CAPACITY		A mm	B mm	INLET/OUTLET DN SIZE			WEIGHT kg
	kW	kcal/h			ΔT =40°	ΔT =50°	ΔT =60°	
TOH350	350	301000	2562	1050	65	-	-	1530
TOH500	500	430000	2865	1270	65	-	-	1900
TOH600	600	516000	3510	1655	65	65	-	2200
TOH1000	1000	860000	3596	1865	100	100	-	3800
TOH1500	1500	1290000	4100	1860	100	100	-	4500
TOH2000	2000	1720000	4230	2010	125	100	-	5100
TOH2500	2500	2150000	4540	2225	125	100	-	6000
TOH3000	3000	2580000	4925	2210	150	100	-	7000
TOH3500	3500	3010000	5140	2400	-	150	-	7500
TOH5500	5500	4730000	6245	2714	-	200	-	9400
TOH6000	6000	5160000	6760	2485	-	200	-	10300
TOH8000	8000	6880000	8625	2950	-	-	200	16500
TOH15000	15000	12900000	11220	3700	-	-	250	33000





HORIZONTAL FLUID HEATERS

The horizontal fluid heater is used from the 100 – 20.000 kW.

The horizontal has own supporting cradle which can bear the heavy coil weight of heaters >10.000 kW. Horizontal fluid heaters are especially suitable for offshore units such as FPSO, FSO's where there are lack of heights within engine room spaces or elevation problems on open deck installations.



Horizontal fluid heater is side fired from end cover, where the burner is horizontally positioned.

TYPE OF FUEL

Light oil, heavy oil, LNG, LPG and similar.

APPROVALS

TUV Germany, TNO the Netherlands and similar.

Classification societies: ABS, Bureau Veritas, DNV, GL, LRS, NKK, RINA, CCS and equal.

The heating systems can also be designed and built to other standards.

GAS FIRED HEATERS

GESAB have supplied several dual fuel fired heaters, which means that the heater can operate on both LNG (Natural Gas) and fuel oil.

The burner is equipped with complete enclosed GUV box and double jacket gas hoses.

This dual fuel burner does also have all fuel oil armatures as well.

The LNG is vaporized in a heat-exchanger and the natural gas is supplied with a pressure of max. 8 barg to the gas pressure regulating valve situated in the GUV box.

The GUV box shall have sufficient forced ventilation in case of a gas leak.

FLOW DIAGRAM WITH THERMAL FLUID HEATER

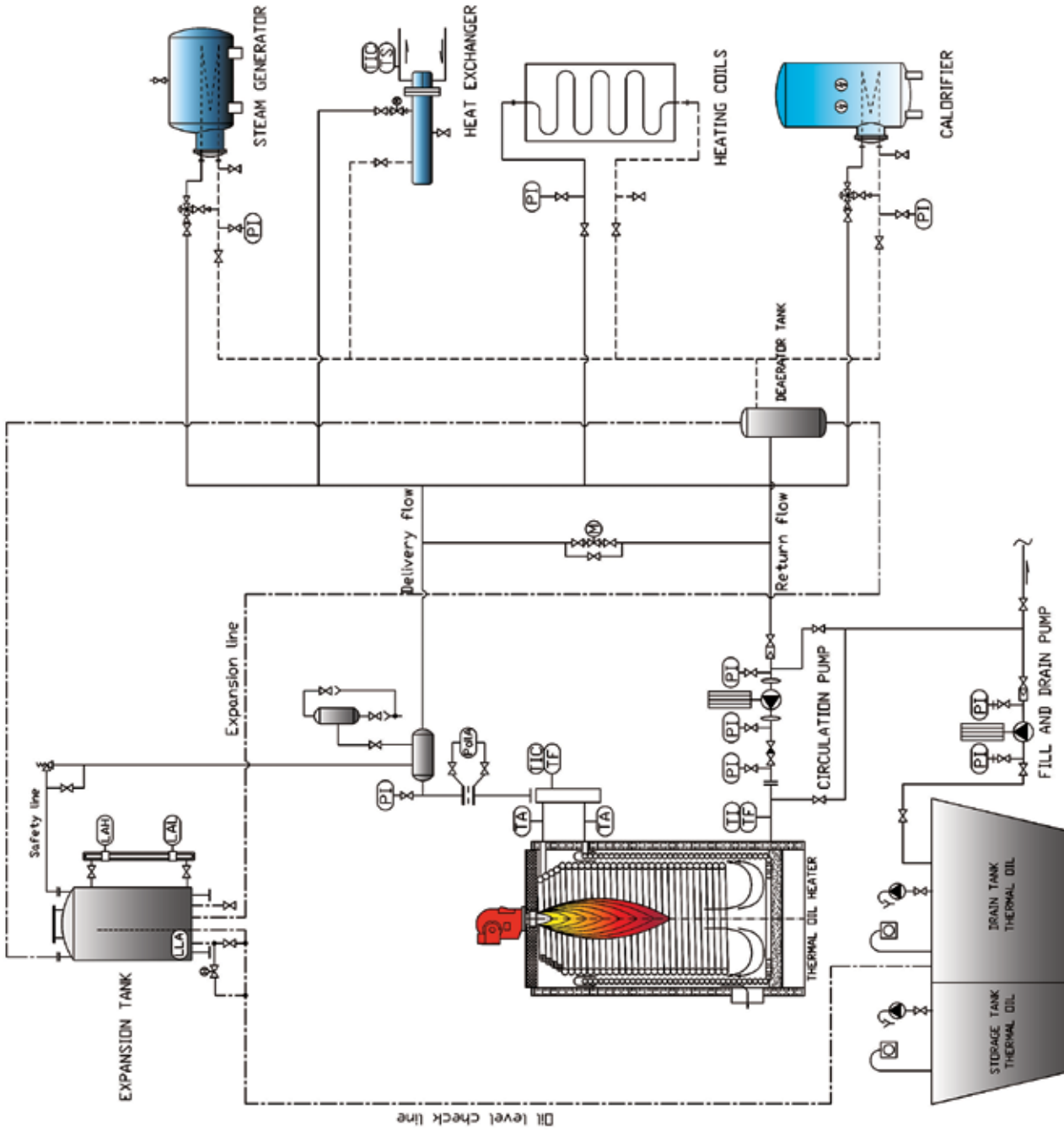

THERMAL FLUID HEATER



EXHAUST GAS HEATER (Economizer) Range 100 - 5000 kW

GENERAL

GESAB - HTI Exhaust Gas Heater, heated by waste gases from the vessel's main engine, is commonly used in satisfying the heat demand of the vessel's bunker heating, accommodation, calorifier water and pre-heaters during the voyage. It may also be sufficient to heat the cargo, subject to heat requirement.

DESIGN AND CONSTRUCTION

The heating surface of the economizer consists of number of spirally wound heating sections which are connected in parallel to a common inlet and outlet manifolds. The high speed of gas flue outside the smooth tubes, create a self cleaning effect.

Inside the economiser, there are water fed ring line fitted with nozzles, for both cleaning of the economiser and for fire extinguishing purposes.

There are also options to get CO₂ fire extinguishing for the economizer and Catamiser.

The lower gas flue transition piece is designed as a water trap to prevent extinguishing water to enter into the exhaust gas ducting from the main engine.

An integrated two flue gas damper section may be installed to modulate the output. Depending on the heat demand the flue gases are by-passed or led through the heating section.

Single emergency damper may also be provided according to rules and regulations.



ADVANTAGES

Reliable, no permanent supervision required.

Precise control and monitoring of temperature and capacity.

Efficient modulation of output from 15% to 100%.

Excellent self-cleaning combustion chamber and tube area design, using high speed exhaust.

Smooth boiler pipes made of certified 37.8 1 steel. Optimal adaption of physical design to confined spaces.

High operational safety by exclusive use of high quality components and safety devices. Heat surface load is calculated to prevent overheating, or cracking, of the heat carrying oil.

Fully automatic operating mode with trouble free operation.

No corrosion in heaters, pipe lines and heat consumers, or other damages normally associated with steam heating systems.

No damages caused by freezing during shut-down periods in low temperatures.

Interconnection of several heaters and consumers possible.

Different temperatures at consumers in secondary circuits possible.

GESAB - HTI Exhaust Gas Heaters are suitable for operation with thermal oil or water.



EXHAUST GAS HEATER (ECONOMIZER)

FLOW DIAGRAM WITH THERMAL FLUID HEATER AND EXHAUST GAS HEATER (ECONOMIZER)

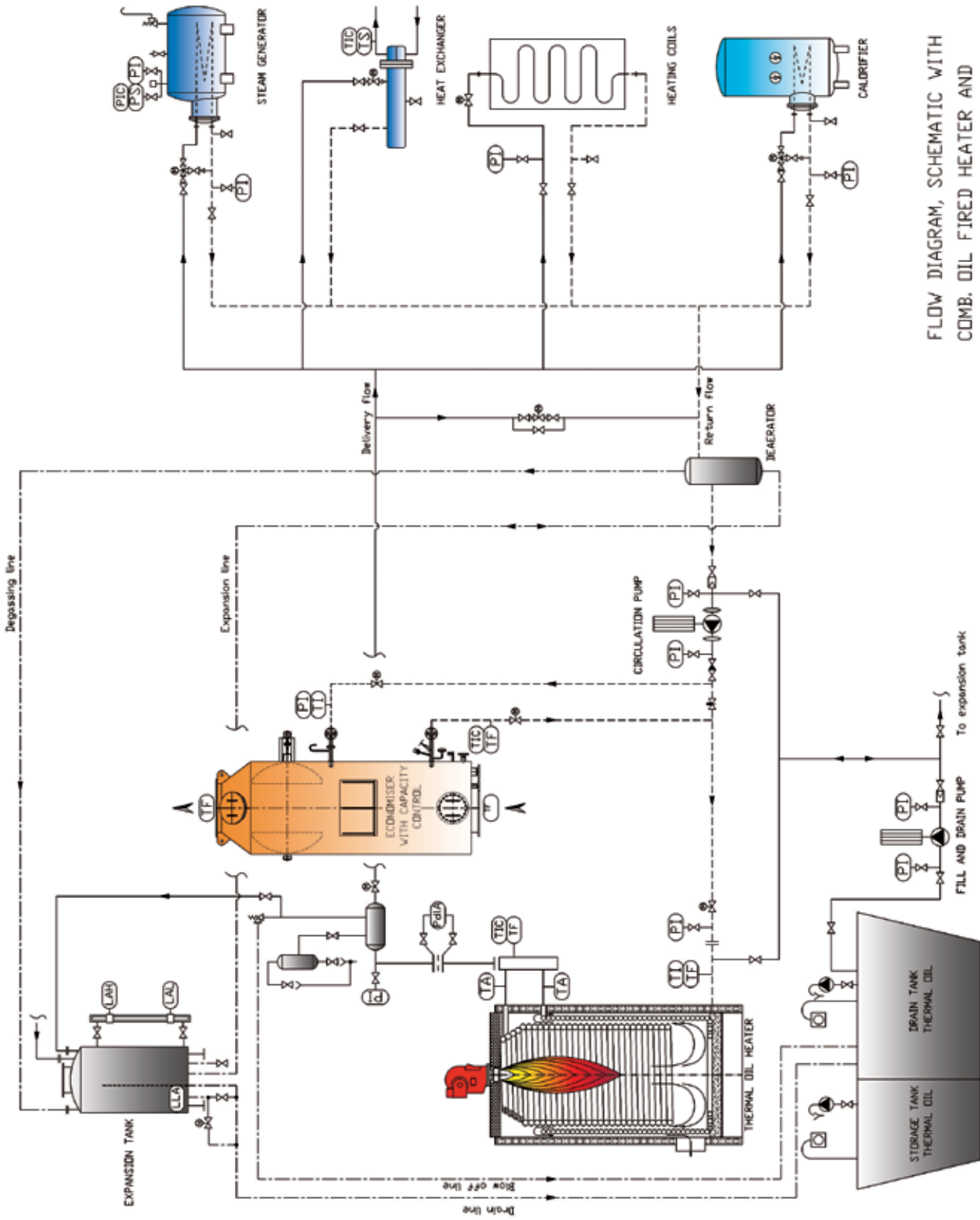

FLOW DIAGRAM, SCHEMATIC WITH COMB. OIL FIRED HEATER AND EXHAUST GAS HEATER (ECONOMISER)

EXHAUST GAS HEATER (ECONOMIZER)



ELECTRO FLUID HEATER



GENERAL

Electric heating elements are arranged centrally in a pipe system, and heated oil will flow parallel. The produced heat of heating elements will be transmitted to hot oil and transferred to heat consumers.

HEATING AND COOLING AS REQUIRE

It is frequently necessary to require a cooling time after a heating period in a discontinuous process. The combination of electric hot oil heater and counter flow heat exchanger makes this possible.



ADVANTAGES

Optimal thermal efficiency

No chimney, no loss of energy due to flue gas.

Defined flow velocity and heating surface loading

Film temperature of heat carrier oil as a result of overheating.

Precise control of flow temperature by constant heat capacity of heating element

Capacity control by multi – or continuous stages

Unproblematic installation at site due to pre erection

Modular units – easy to maintain

FLOW DIAGRAM WITH ELECTRO FLUID HEATER

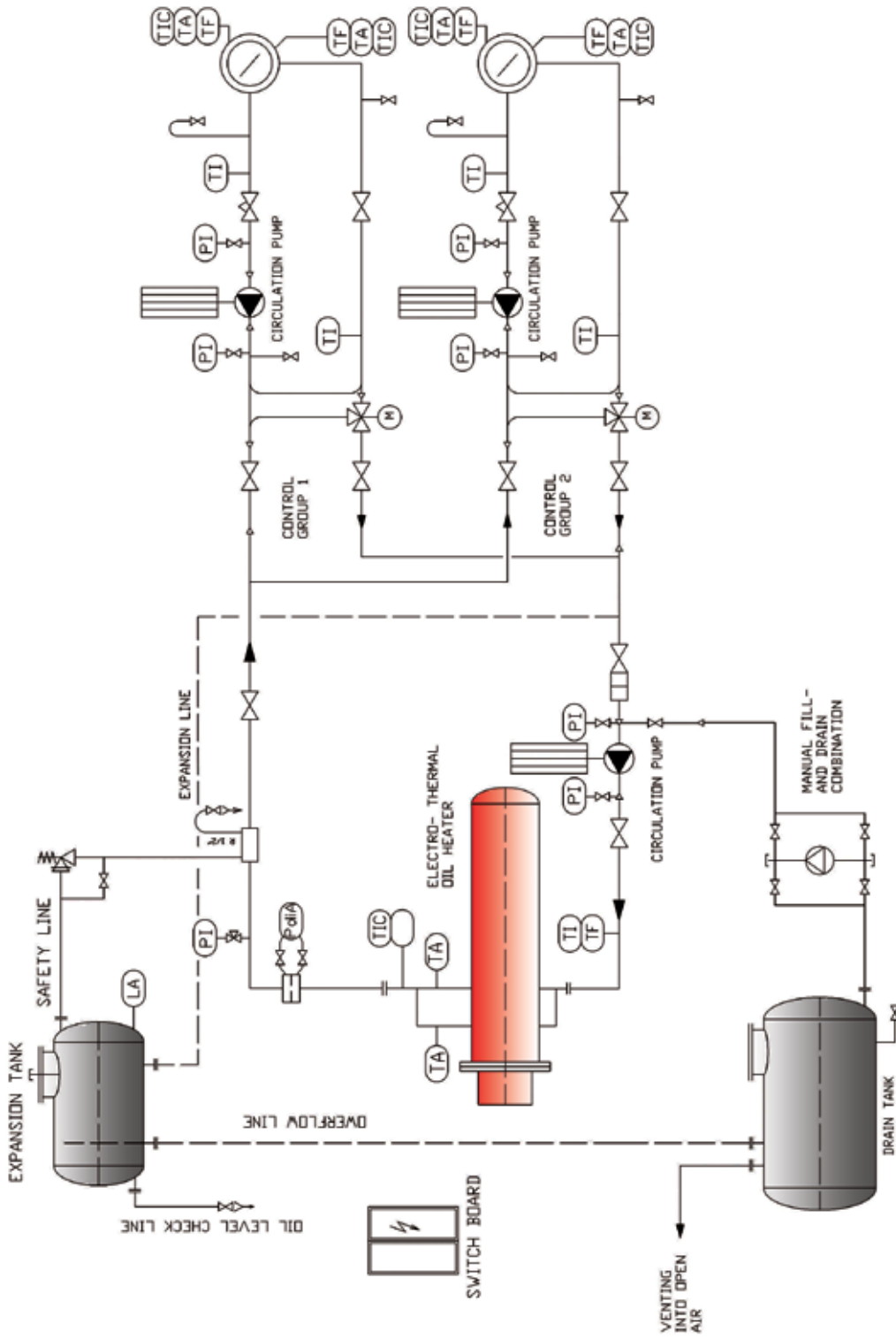

ELECTRO FLUID HEATER



CONTAINER & SKID UNITS

Thermal fluid heaters can be delivered as a complete heating system, “plug and play” unit, in a container or a skid, fitted with all necessary tanks, pumps, switchboards, valves and gauges.

Container and skid units are built in a variety of configurations according to customer requirements. It can be for deck installation on ships or rigs, where no boiler room exists or engine room which cannot accommodate the boiler plant.

It can also be complete fully assembled unit to be lifted into a construction section inside the ship or rig. The design can follow the clients requirements and requests as far this is possible.





CONTAINER & SKID UNITS

HEATING COILS



Fig: Heating Coil Tower

GENERAL

GESAB Thermal Fluid Heating Systems have been installed in a large number of chemical tankers, ferries and cargo carriers during the last years. Thermal fluid, fed directly to various types of heating coils, is used in most of the chemical and product tankers. The thermal fluid transfers heat to the consumers in engine room, accommodation heating, heating coils in the bunker tanks and cargo tanks.

CONSTRUCTION AND DESIGN

To maximize heating efficiency, both horizontal and vertical Heating Coils can be used in the cargo tanks for oil products or chemicals. The pipe materials are stainless steel, CuNiFe alloys or carbon steel. The GESAB Heating Coil Calculation computer based program, HCC, optimize the needed coil dimensions and installed coil lengths for each cargo tank and minimizes costs of pipe work and material consumption.

VARIETY OF APPLICATIONS OF THERMAL FLUID

Today's modern applications include the use of Thermal Fluid Heaters for boiling shrimps (heat exchanger), heating steam generator in cod-liver-oil boiler or service the chillers for freezing plant on board factory trawler. Artic/Antarctic survey vessels and Offshore rigs for harsh environments use thermal fluid as the prime heat distributing media making domestic hot water, warm air and radiant heating for accommodation and helicopter hangars.

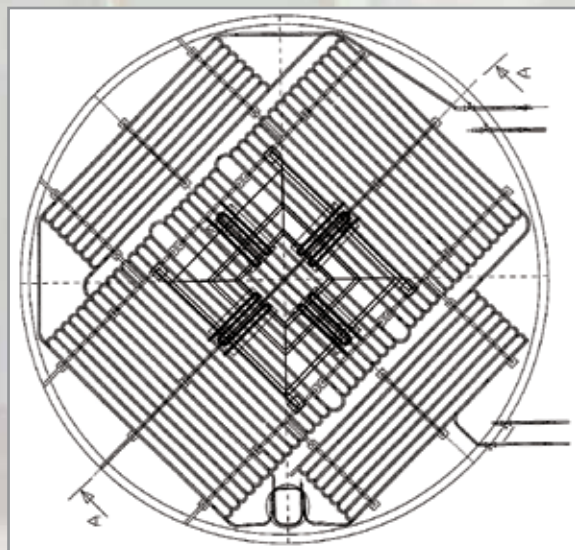

FLOW DIAGRAM FOR CARGO HEATING SYSTEM WITH HEATING COILS (CHEMICAL TANKER)

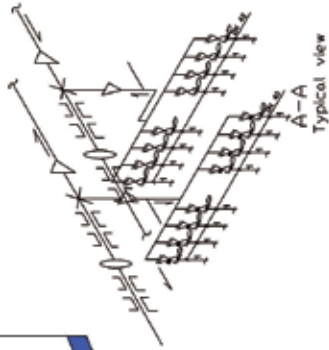
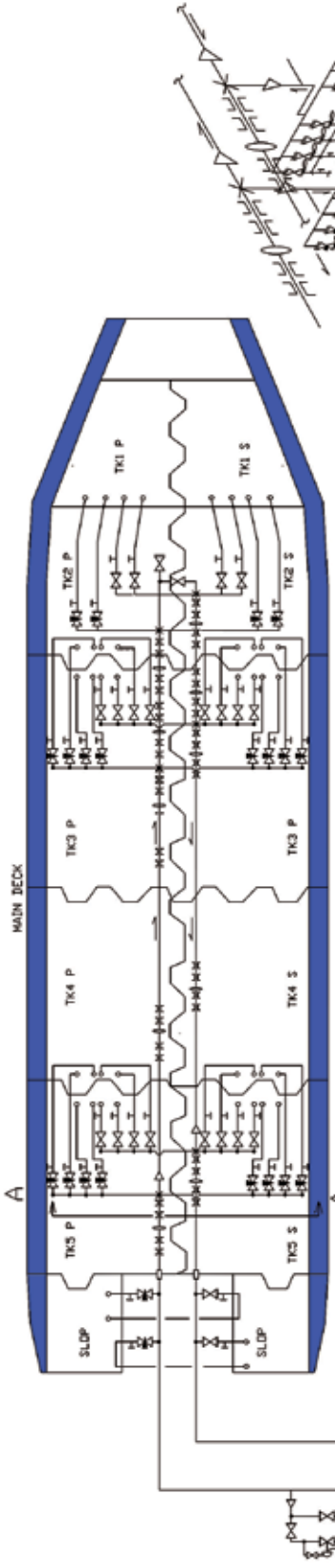

- GLOBE VALVE
 - GLOBE VALVE WITH REGULATING CONE
 - NON RETURN VALVE
 - PNEUMATIC OVERFLOW VALVE
 - TEMPERATURE CONTROL VALVE
 - SAFETY VALVE
 - PRESSURE REDUCING VALVE
 - EXPANSION BELLOW
 - DRAIN PLUG
 - SLAB SUPPORT X FIX POINT
 - TURN FLANGE
-
- LPA ALARM, LOW PRESSURE
 - LHA ALARM, HIGH PRESSURE
 - PI PRESSURE INDICATOR
 - TIC TEMPERATURE CONTROLLER
 - LAL ALARM, LOW LEVEL
 - LHA ALARM, HIGH LEVEL
 - TI TEMPERATURE INDICATOR
 - TT TEMPERATURE TRANSMITTER

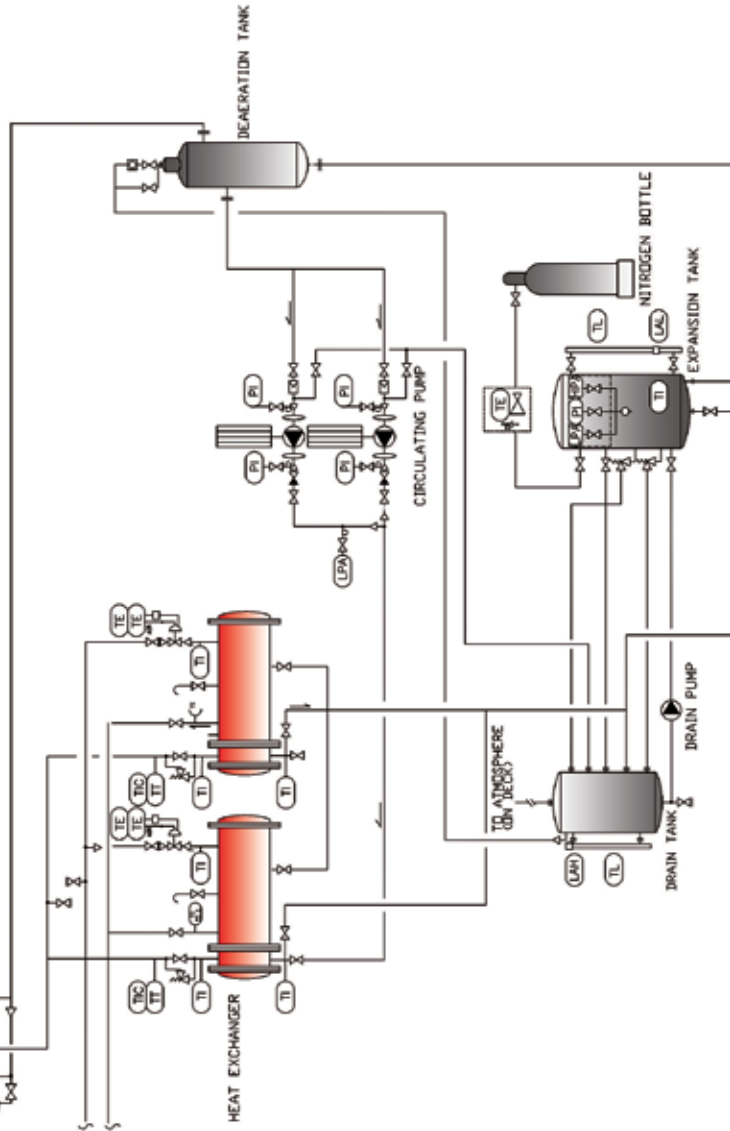

HEATING COILS



CARGO HEATERS (Deck Heaters)



GENERAL

Cargo heater (deck heater), tube type for installation on open deck or in closed deck trunks.
Heating media: Thermal Oil, Hot Water or Steam
Capacity range: 100 - 2000 kW
Material: Stainless steel AISI 316 L (Standard), or other on request.

ADVANTAGES

Simple installation compare to heating coils.
More efficient cleaning of cargo tanks due to fewer obstacles and "shadows".
Easy service and cleaning of deck heaters



FLOW DIAGRAM FOR CARGO HEATING SYSTEM WITH CARGO HEATERS

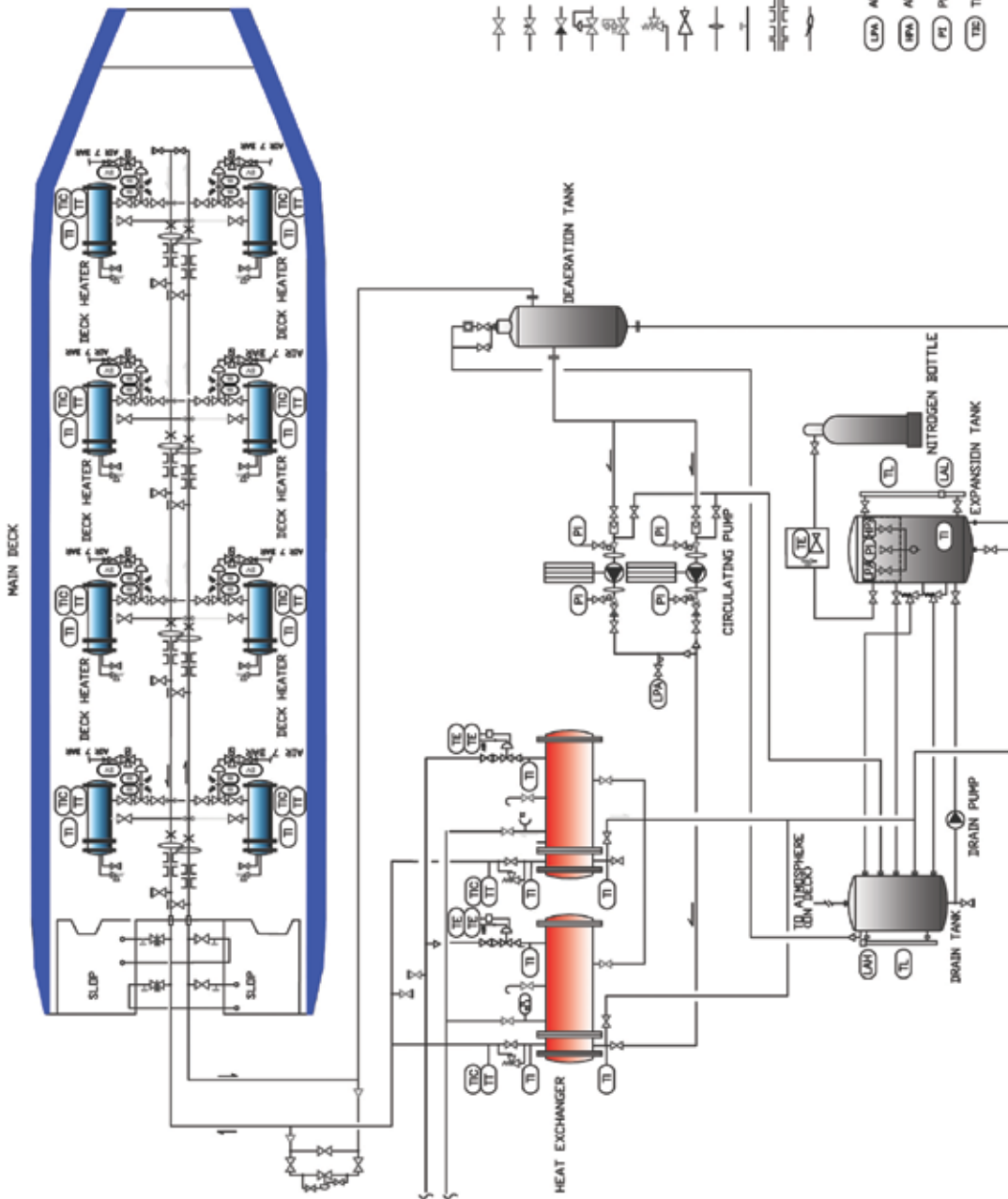

- GLOBE VALVE
 - GLOBE VALVE WITH REGULATING CONE
 - NON RETURN VALVE
 - PNEUMATIC OVERFLOW VALVE
 - TEMPERATURE CONTROL VALVE
 - SAFETY VALVE
 - PRESSURE REDUCING VALVE
 - EXPANSION BELLOWS
 - DRAIN PLUG
 - SLIDE SUPPORT X FIX POINT
 - TURN FLANGE
-
- LPD ALARM, LOW PRESSURE
 - LAL ALARM, LOW LEVEL
 - LPH ALARM, HIGH PRESSURE
 - LHL ALARM, HIGH LEVEL
 - PI PRESSURE INDICATOR
 - TI TEMPERATURE INDICATOR
 - TC TEMPERATURE CONTROLLER
 - TT TEMPERATURE TRANSMITTER

CARGO HEATERS (DECK HEATERS)



GESAB HEATING SYSTEM ACCESSORIES

STEAM GENERATORS (Unfired)

Steam generators for heating, cleaning and de-icing purposes. These are particularly requested for chemical tankers, where the cleaning requirement is an issue.

DESIGN: Horizontal or vertical, tube type.

HEATING MEDIA: Thermal Oil or Hot Water

CAPACITY RANGE: 100 – 10.000 kg/h

STEAM PRESSURE RANGE: 3 - 10 bar (g)

MATERIAL: Mild Steel or Stainless Steel in various qualities.



Fig: Horizontal Steam Generator

ADVANTAGES

Simple installation, no exhaust stack or fuel supply system needed.
More compact than conventional oil fired steam generators.
Easy service and cleaning due to simple dismantling of deck heaters.

CIRCULATION PUMP (centrifugal type)

Pumps are used in all forced circulation heating systems. GESAB provides the most suitable type and make depending on the application. The thermal fluid flow is matched to the design and capacity of heaters.

FLOW CAPACITIES: 5 - 750 m³/h

TYPES: Free standing pump with separate motor

In-line, vertical type

In-line, horizontal type

SEALING TYPES

Mechanical seal (Standard)

Magnetic coupling

MATERIAL

Nodular cast iron (GGG-40.3)

Stainless Steel (AISI 316 L)

Other material on request

GESAB also provides completely assembled pump units in one to three pump set configurations.



Fig: Pump Unit Horizontal Circ Pumps



Fig: Pump Unit Vertical in-line Circ Pumps

GLOBE VALVES with bellow sealing

Globe valves are used for proper tightness and more accurate flow control in both thermal oil and hot water systems. For thermal oil applications, the standard is to fit bellow sealing in addition to the regular stuffing box.

SIZES: ND 15 - 350
PRESSURE CLASSES: PN 16 - 40

MATERIAL
Nodular cast iron (GGG-40.3), Standard
Cast steel (GS-C25)
Other material options can be provided on request

TYPES
Flange connections
Welded ends connections



Fig: Flanged Globe Valve

QUICK CLOSING/OPENING VALVES

For thermal fluid systems where the class rules and regulations requires quick closing and drainage units (valves).

SIZES: ND 15 - 350
PRESSURE CLASSES: PN16 - 40

MATERIAL
Nodular cast iron (GGG-40.3)
Other material options can be provided on request

TYPES
Hydraulic actuated
Pneumatic actuated
Wire release



Fig: Flanged Quick Opening Valve

CONTROL VALVES

Control valves are used for temperature and flow control. The valve is fitted with bellow sealing and stuffing box.

SIZES: ND 15 - 350
Pressure classes: PN16 - 40

MATERIAL
Nodular cast iron (GGG-40.3)
Other material options can be provided on request

TYPES
Pneumatic actuator
Electrical actuator



Fig: Electric & Pneumatic Control Valve



GESAB HEATING SYSTEM ACCESSORIES

BURNERS

GESAB equips heaters with suitable burners according to client's preferred fuel types.

A range of customized burners can be provided:

Gas oil burners (ISO-8217 DMA, DMB, DMC and DMX)

Combined Gas oil / Heavy fuel oil burners

IF 380 (Viscosity 380 cSt at 50°C)

Heavy oil / Sludge oil burners (Viscosity 700 cSt at 50°C)

Gas burners (LPG and LNG)

Other types of burners can be provided upon request.



Fig: Air Atomising Burner for MDO and HFO Combustion



Fig: LNG burner

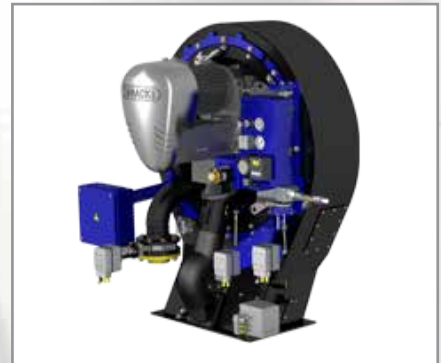

Fig: Rotary Cup Burner for HFO and Sludge Combustion



Fig: Gas valve unit (GVU)

CONTROL CABINETS AND SWITCHBOARDS

GESAB designs and manufactures control cabinets in accordance with the client's demands, which may range from a simple solution to the most advanced PLC controlled units with operation panels (OP). All switchboards are approved and tested according to class society rules and regulations.

ADVANTAGES

Integration of external control and monitoring points can easily being achieved.

Integration of motor starters.

Optional features can be provided upon customer request.



Fig: Typical Control Cabinet

HOT WATER CALORIFIERS

The hot water cylinder is available in nine storage capacities. The secondary water can be heated by electric immersion heaters or indirect flow and return heating from a boiler. If required, the cylinder can be supplied for connection to both heat sources.

SIZES: 50 - 2500 liters



Fig: Typical Hot Water Calorifier

HEAT - EXCHANGERS

Tank Cleaning Heaters, Intermedium Heaters and Dumping Coolers used in the system are provided and designed according to customers request.



Fig: Tube Bundle Heat - Exchanger



Fig: Plate Heat - Exchanger



ENERGY MANAGEMENT SYSTEM

The energy management unit (EMS) is a system for temperature controlling various consumers throughout the vessel such as engine room tanks, heatexchangers for modules, etc. This means you have a central unit where you can operate temperature for all consumers, see trends and link this information to main VMS aboard. This system can also operate circulation pumps and thermal fluid heaters in sequences where several heaters and pumps are incorporated in the thermal fluid system.

The EMS has the ability of distributing energy according to selected priority of consumers. This means that EMS will be programmed to heat and switch off heating of certain consumers depending on which one has most priority of the available heat energy from the economizer. When all priority group is heated at same time and the set temperature of each consumer is not possible to keep, due to lack of heat supply from economizer.

Then the system start with switching of third priority consumer group, subsequently the EMS wait for a certain response time (adjustable time delay depending on design of system), where EMS will measure if temperature are steady in priority consumer or not.

If temperature still decreasing in the consumers of priority 1 & 2, the priority group 2 will be switch off as well. When the temperature start to raise in priority group 1 and reaches its temperature set point, EMS will automatically switch on priority group 2 and then priority group 3 in sequence. The sequence is depending on available heat accordingly.

EXAMPLE ON FIRST (1) PRIORITY CONSUMERS:

- Booster modules
- Purifiers/Separators
- Essential pre-heaters

EXAMPLE ON SECOND (2) PRIORITY CONSUMERS:

- Service tank
- Settling tank

EXAMPLE ON THIRD (3) PRIORITY CONSUMERS:

- Storage tanks
- Drain tanks
- Sludge tanks

PANELS AND PLC CONTROLLERS

Every EMS consists of PLC (Programmable Logic Controller) and touch panel with color screen. PLC is a heart of the system - this is where controllers for consumers are implemented. Each consumer has its own control loop built with a PID controller, which can be adjust independently to meet individual needs of the consumer. Software for each EMS is made individually to meet user requirements.



EMS operator panel is where status, parameters, warnings and alarms of the system are displayed. It is also an easy to use, intuitive, similar to that of a mobile phone keypad, interface to interact with PLC.



All system settings such as consumer priorities, PID parameters, analog signals can be changed in the panel - without unnecessary changes in PLC software.

Variety of touch panel sizes: from 4" up to 22" - typically 7" or 9". Also available versions with buttons if requested(size 4" to 15").



System data (trends, alarms and warning history) are easy to export to external memory (MMC card or USB Memory Dongle).



EMS can be connect to Ship's Management System via Profibus/Modbus (both RS485 or Ethernet).



Panel - switchboards are designed and done individually for request. Built from high quality and modern components.

USER'S INTERFACE

Screens in the panel are designed in cooperation with the user to provide a user friendly interface, with all the functions needed to control, monitor and manage the system.

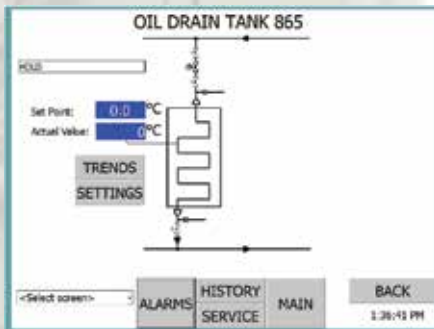

Individual screen for each consumer showing most important parameters, with buttons for a quick switching to global screens (alarm list, main screenetc).

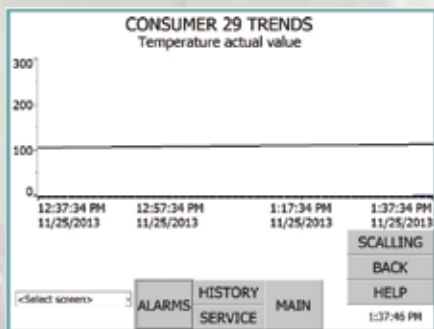

Trends screen for review of last history of the monitored parameters with possibility of changing settings of a graph view.



Adjustments of parameters in PID controllers, calibrating of the signals etc

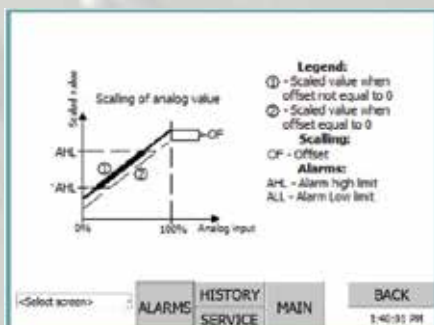

Help screens which explains parameters showed on other screens and will work as a guide during controller setting.



CATAMISER®

GENERAL

Catamiser® is a combined unit for waste heat recovery and NO_x reduction of exhaust gases.

The unit will meet NO_x requirements according to IMO Tier III and makes the engine system more energy efficient.

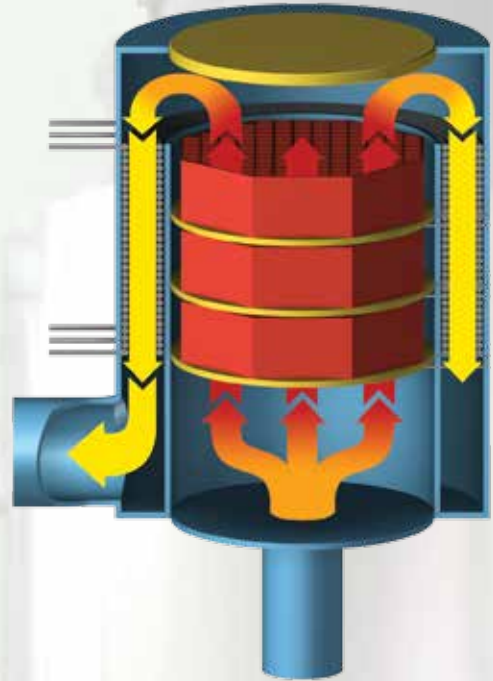

DESIGN AND CONSTRUCTION

NO_x reduction is achieved by Selective Catalytic Reduction (SCR). The unit is surrounded by spirally wound heating coils. GESAB's long experience in Exhaust Gas Heaters (Economisers) ensures efficient waste heat recovery.

Advantages compared to two separate units (SCR and Economiser)

- More cost effective
- Reduced weight
- Less space required
- One supplier will service the after treatment system

DIMENSION SKETCH CATAMISER®

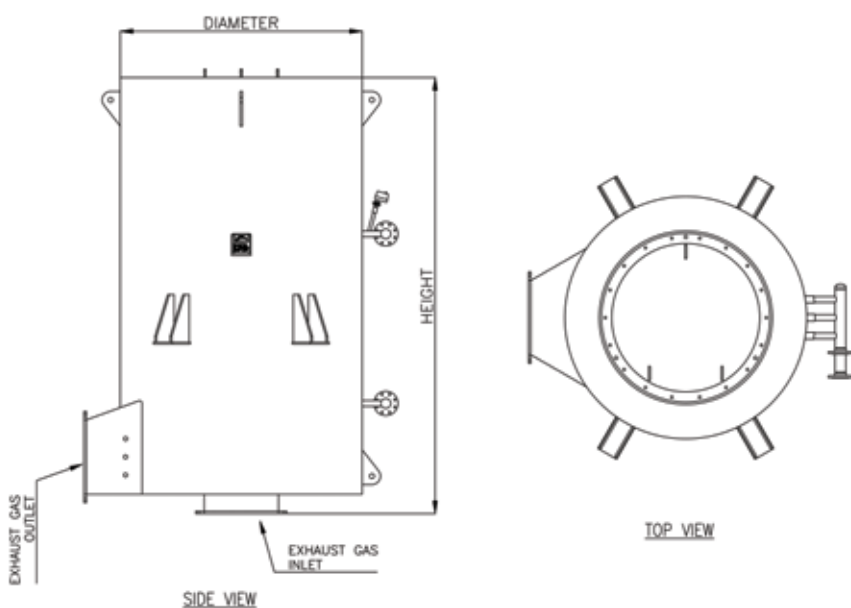

TABLE OF DIMENSIONS CATAMISER®

ENGINE POWER MCR	EXHAUST PIPE DIAMETER	HEAT POWER	DIAMETER	HEIGHT	OPERATING WEIGHT
kW	DN	kW	mm	mm	kg
700	350	140	1 180	2 700	1 400
1 000	400	200	1 540	2 900	2 400
1 700	500	340	1 660	3 200	3 900
2 000	600	400	1 780	3 400	4 500
2 500	600	500	2 000	3 600	5 700
3 000	700	600	2 140	3 800	7 000
4 000	800	800	2 470	4 400	10 500
6 000	900	1 200	2 930	5 100	16 000



CATAMISER® HORIZONTAL TYPE

Catamiser® is also available as horizontal type. Horizontal installation is often done at large units or when there are specific installation requirements.



CATAMISER® SLIM TYPE

SCR and Economiser units are assembled in a straightway type (slim type). By combining the units, the total length can be reduced. By that, only one unit needs to be installed instead of two units with fittings in between.

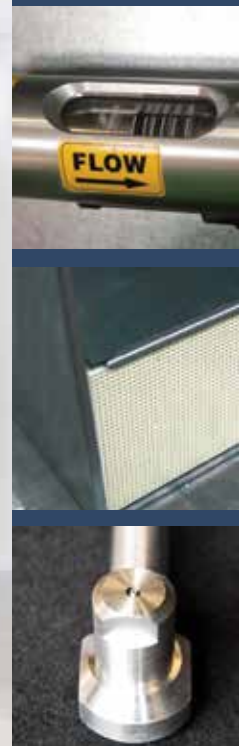

SCR (SELECTIVE CATALYTIC REDUCTION)

GENERAL

As an alternative to Catamiser® system, GESAB can deliver standard SCR systems that will meet future NO_x requirements according to IMO Tier III.



DESIGN AND CONSTRUCTION

NO_x reduction is achieved by Selective Catalytic Reduction (SCR). The catalytic elements are placed in a steel reactor.

Advantages compared to separate suppliers of SCR and Economiser

- Built from GESAB's long experience from after treatment systems in own production facilities
- GESAB performs service on both SCR and Economiser



DIMENSION SKETCH SCR

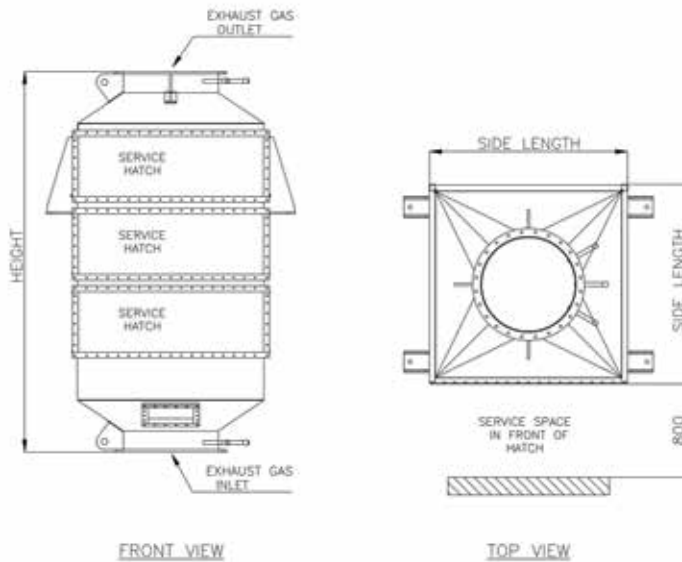
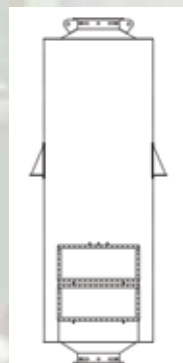
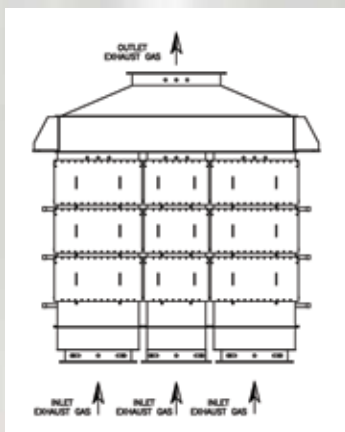

TABLE OF DIMENSIONS SCR

ENGINE POWER MCR	EXHAUST PIPE DIAMETER	SIDE LENGTH	HEIGHT	OPERATING WEIGHT
kW	DN	mm	mm	kg
400	250	590	1 700	600
750	350	740	1 800	800
1 150	400	900	2 000	1 100
1 600	500	1 060	2 700	1 700
2 200	600	1 220	2 900	2 200
3 000	700	1 380	3 100	2 700
3 700	700	1 530	3 200	3 300
4 500	800	1 690	3 400	3 900
5 500	900	1 850	3 500	4 500
6 500	1 000	2 010	3 700	5 200
8 000	1 100	2 170	3 900	6 000
9 000	1 200	2 330	4 000	8 100



SCR MULTI-ENGINES

Exhaust gas inlet pipes from several engines are connected into one common SCR reactor. The different SCR chambers are separated by internal walls. SCR reactor has one common Exhaust gas outlet pipe.

SCR & SILENCER

SCR reactor and Silencer are combined into one unit. The combined unit will be shorter than a separate SCR and Silencer, thereby reducing necessary installation space.

FLOW DIAGRAM SCR SYSTEM

SCR (SELECTIVE CATALYTIC REDUCTION)

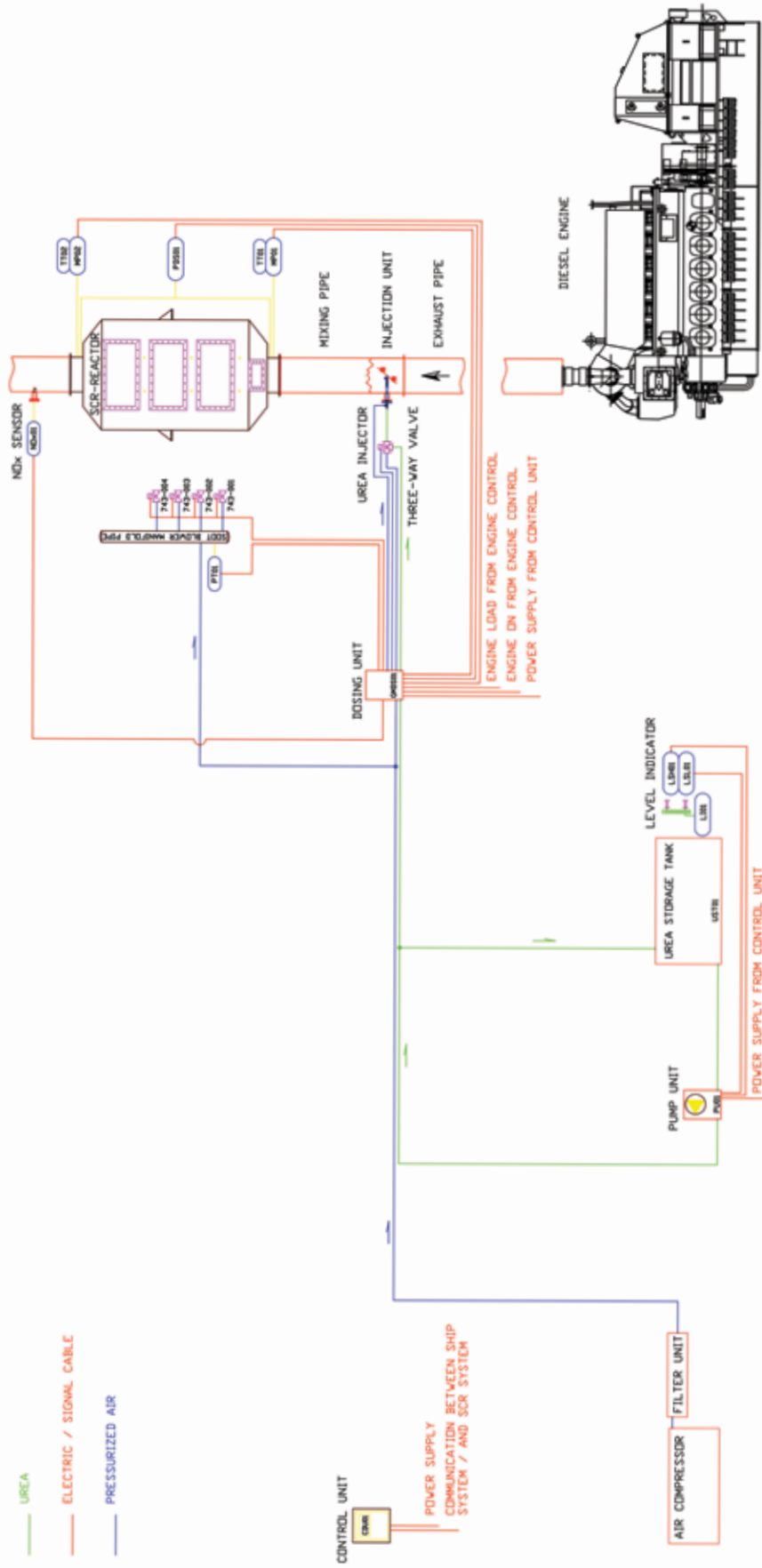

SCR (Selective Catalytic Reduction) SYSTEM FOR CLEANING OF NO_x FROM DIESEL ENGINE EXHAUST GASES.

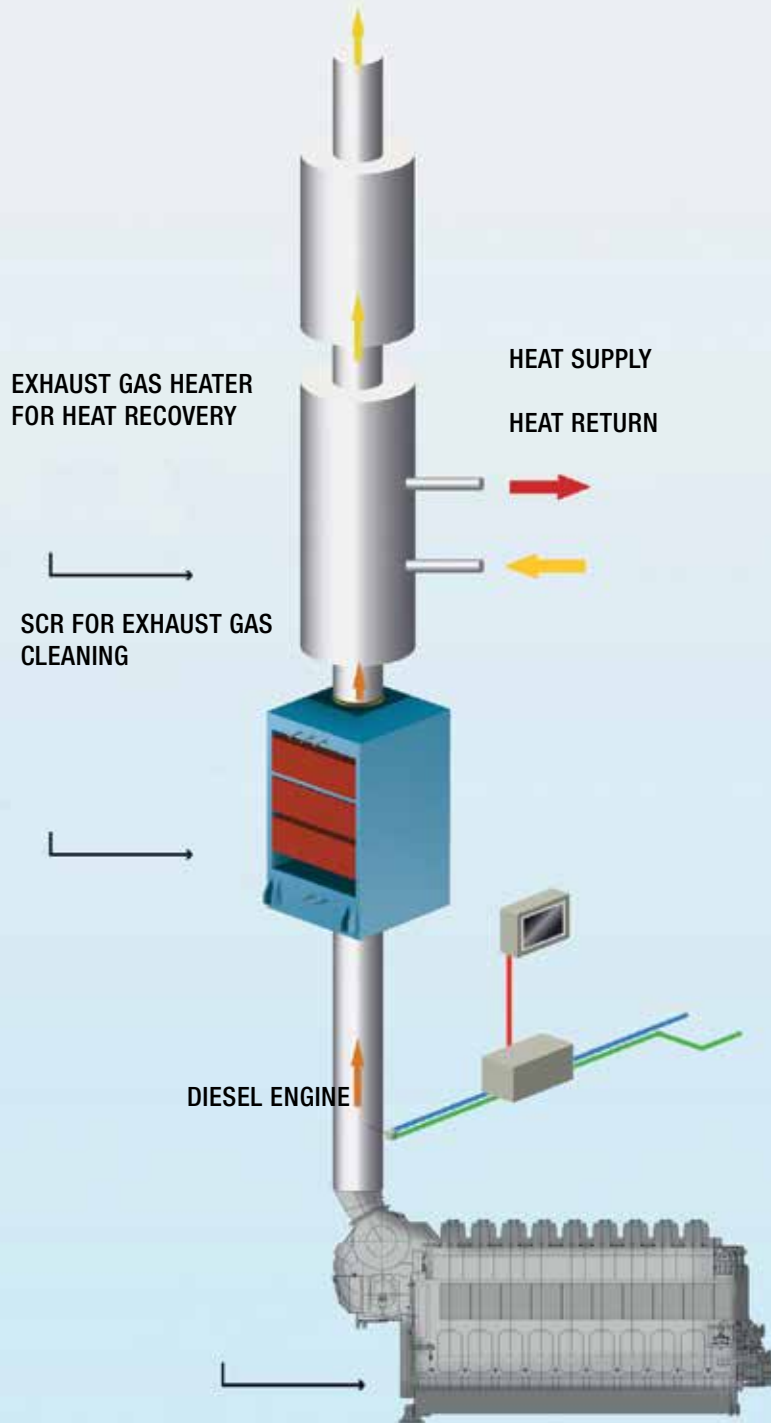

SCR (SELECTIVE CATALYTIC REDUCTION)

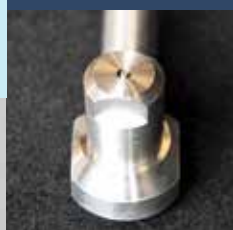

SCR-Catamiser®

Exhaust gas cleaning with waste heat recovery

NO_x REDUCTION

CO₂ REDUCTION

FUEL SAVING

DAMPER SYSTEM MAKING IT POSSIBLE TO USE ONE COMMON CATAMISER® / SCR / EXHAUST GAS HEATER FOR SEVERAL DIESEL ENGINES.

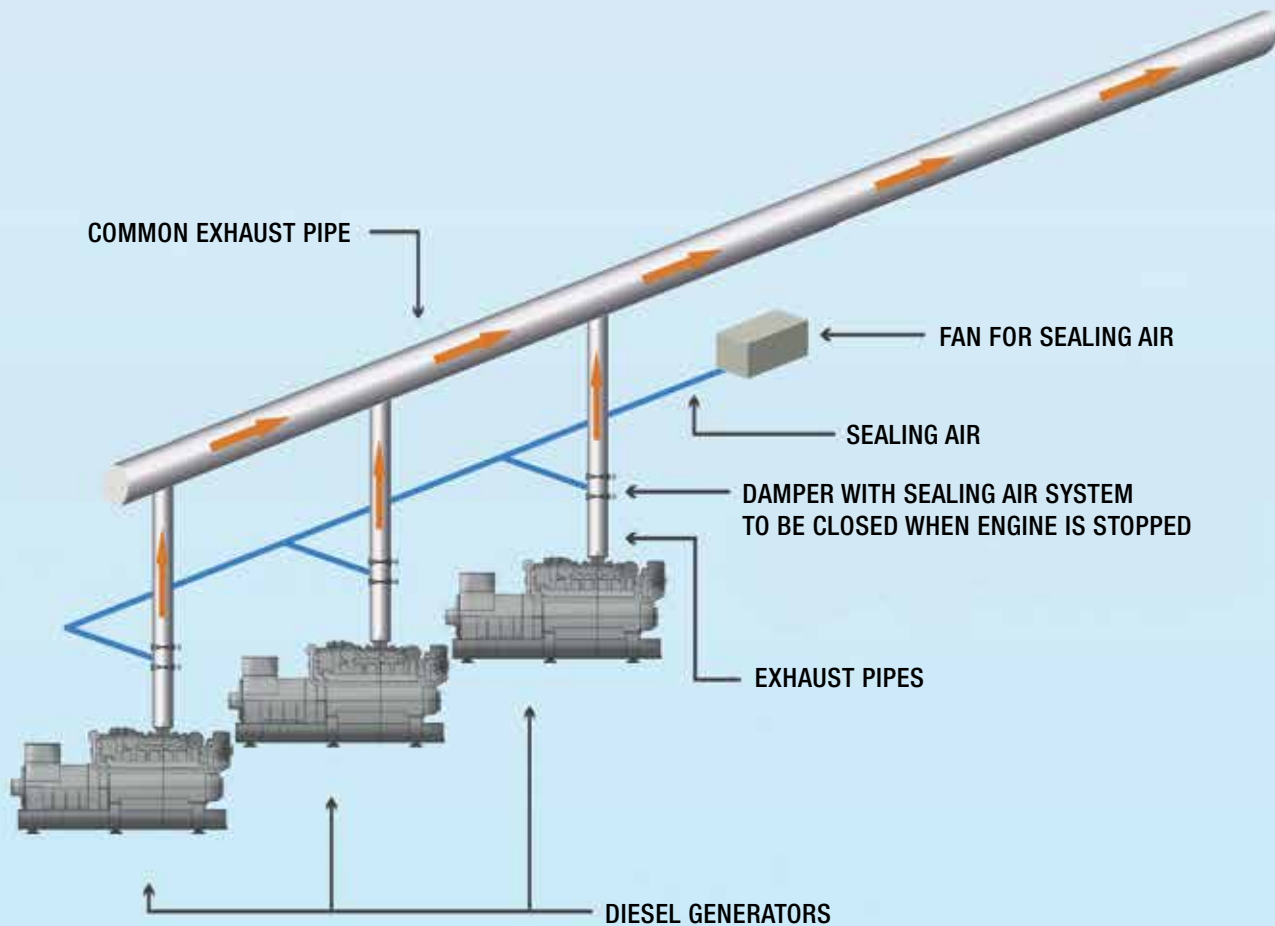

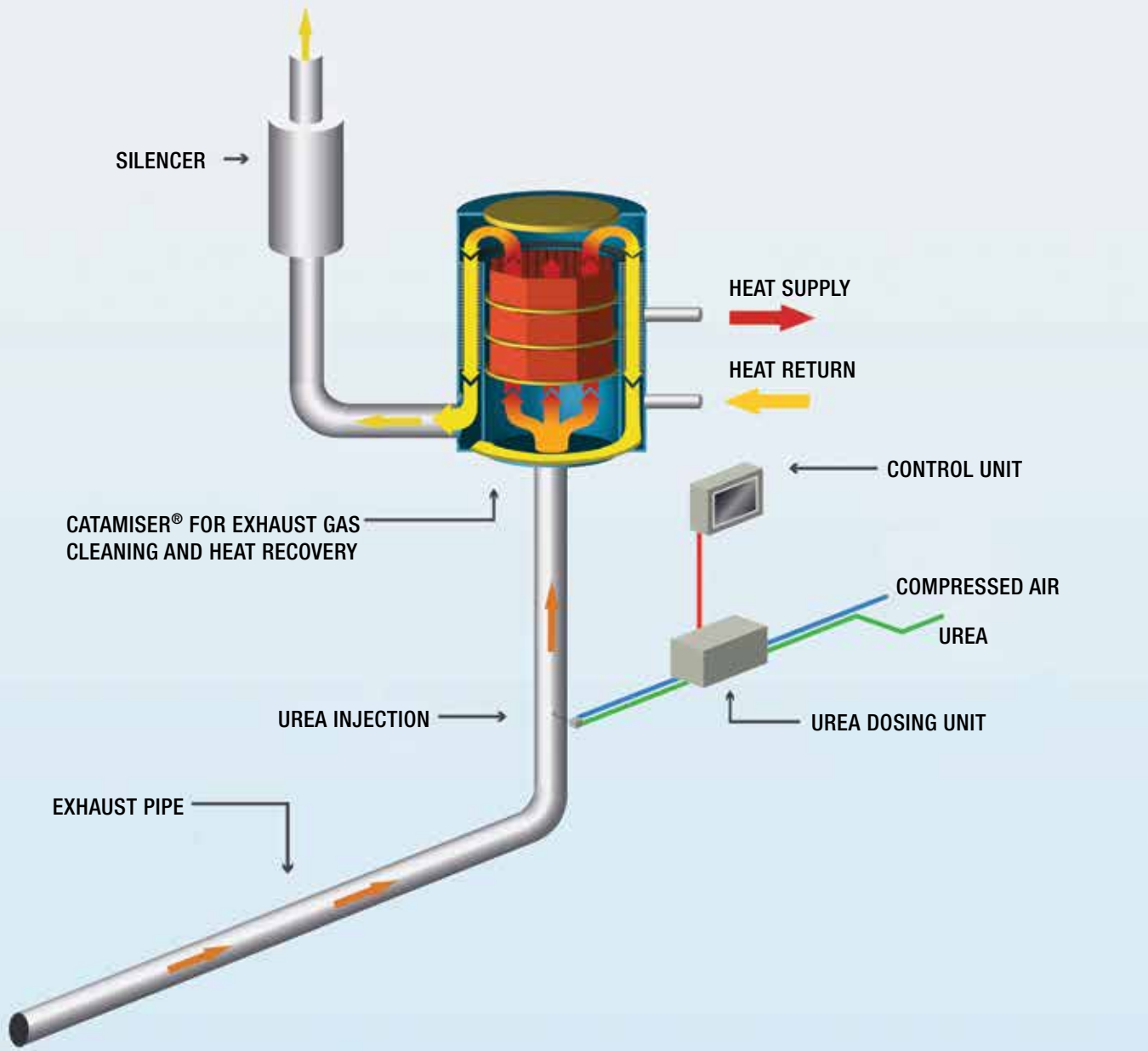

CATAMISER® SYSTEM
COMBINED SCR AND ECONOMISER FOR EXHAUST
CLEANING AND HEAT RECOVERY IN COMMON UNIT.

SCR-Catamiser®
Exhaust gas cleaning with waste heat recovery

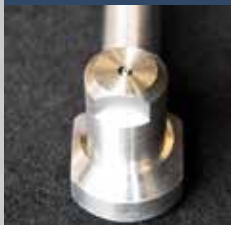

ACCESSORIES SCR & CATAMISER®



CONTROL AND DATA LOGGER UNIT

The Control and Data logger unit controls and visualizes all necessary SCR operation.



PUMP UNIT

The Pump unit feeds the ring line with urea from the urea storage or day tank.



DOSING UNIT

The Dosing unit consists of all necessary fittings and dosing pump for a safe and precise urea dosing.



INJECTION UNIT

The Injection unit contains of a boss for the urea injector and a mixer which evenly spread the urea in the exhaust gas pipe.

ACCESSORIES SCR & CATAMISER®

INJECTOR

The urea injector atomize urea into the exhaust gas pipe.



SOOT BLOWER

The soot blower unit guaranties a periodic cleaning from the catalytic elements SCR.



CATALYTIC ELEMENT

In the Catalytic element, the NO_x is reduced by the catalytic reaction of NO_x and ammonium into nitrogen.



NO_x SENSOR

The NO_x sensor is used for continuously measure NO_x level which controls the urea injection.

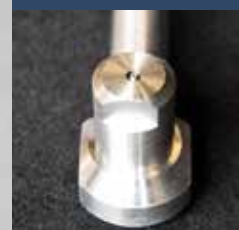
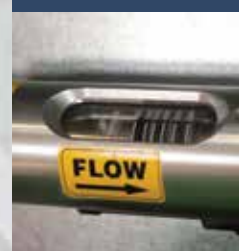





GESAB'S PRODUCTS ARE DISTRIBUTED WORLDWIDE

GESAB

Located in Gothenburg, the maritime center of Scandinavia, GESAB has over 50 years of experience in delivering heating and NO_x reduction systems for marine and industrial applications. GESAB's quality products provide cost effective and competitive solutions to the heating needs or NO_x regulation in all types of ships and industries.

GESAB ENGINEERING AND PRODUCT QUALITY

The well managed GESAB ensures the highest quality in all phases of product design, procurement, planning and production. By continuously developing new technology and production methods, GESAB can meet the constantly changing market demands. A highly skilled and service oriented staff ensures that the customers gets the specified product in a cost effective and timely fashion.

ADVANCED LOGISTICS

Online connections with our local agents ensure complete control of worldwide product delivery. Our experienced staff keeps the customer continuously informed about current status of design, fabrication, transportation, commissioning, start-up, inspection testing etc.

GESAB'S PRODUCT RANGE:

- Thermal Fluid Heaters type TOH up to 20.000 kW with oil or gas firing.
- Hot Water Heaters type HWH up to 20.000 kW with oil or gas firing.
- Exhaust Gas Heaters (Economizer) type EGH up to 5 000 kW.
- Electro Fluid Heaters type EHE up to 3 000 kW.
- Unfired Steam Generators SG upto 10 Ton/h.
- Indirect heated Hot Water Generator.
- Pipe line construction for heat carrier oil, hot water, steam.
- Heat exchanger (counter flow units for heat carrier oil, water, steam).
- Ready-to-use heat - carrier oil plants with indirect steam and water production.
- Process temperature controllers heating / cooling.
- Fully assembled boiler skid units.
- Fully assembled boiler container units.
- SCR reactors - up to 10 000 kW engine power, Vertical/Horizontal with Multi-engine or combined with silencer.
- Catamiser® - up to 10 000 kW engine power, Vertical/Horizontal and Slim type.

GESAB



GESAB

Göteborgs Energy Systems AB
Ångpannegatan 15A
S - 417 05 GÖTEBORG
SWEDEN

Phone: +46 (0) 31 744 19 50
Fax: +46 (0) 31 779 78 41
Email: gesab@gesab.net
Web: www.gesab.net



GESAB (Shaoxing)

Emission Systems Co., Ltd
Sanjie Industry Zone, Sanjie Town
Sheng Zhou City, Shaoxing
Zhe Jiang Province 312452
P.R. China

Phone: +86 (0) 575 8308 0880
Fax: +86 (0) 575 8308 0880
Email: cs-gesab@gesabcn.cn
Web: www.gesabcn.cn



HTI-GESAB

Sauerbruchstr. 11
D - 25741 Ellerau
GERMANY

Phone: +49 (0) 4106 700 90
Fax: +49 (0) 4106 700 999
Email: Info@HTI-Ellerau.de
Web: www.hti-ellerau.de